

■ Mounting Dimensional Description AS39

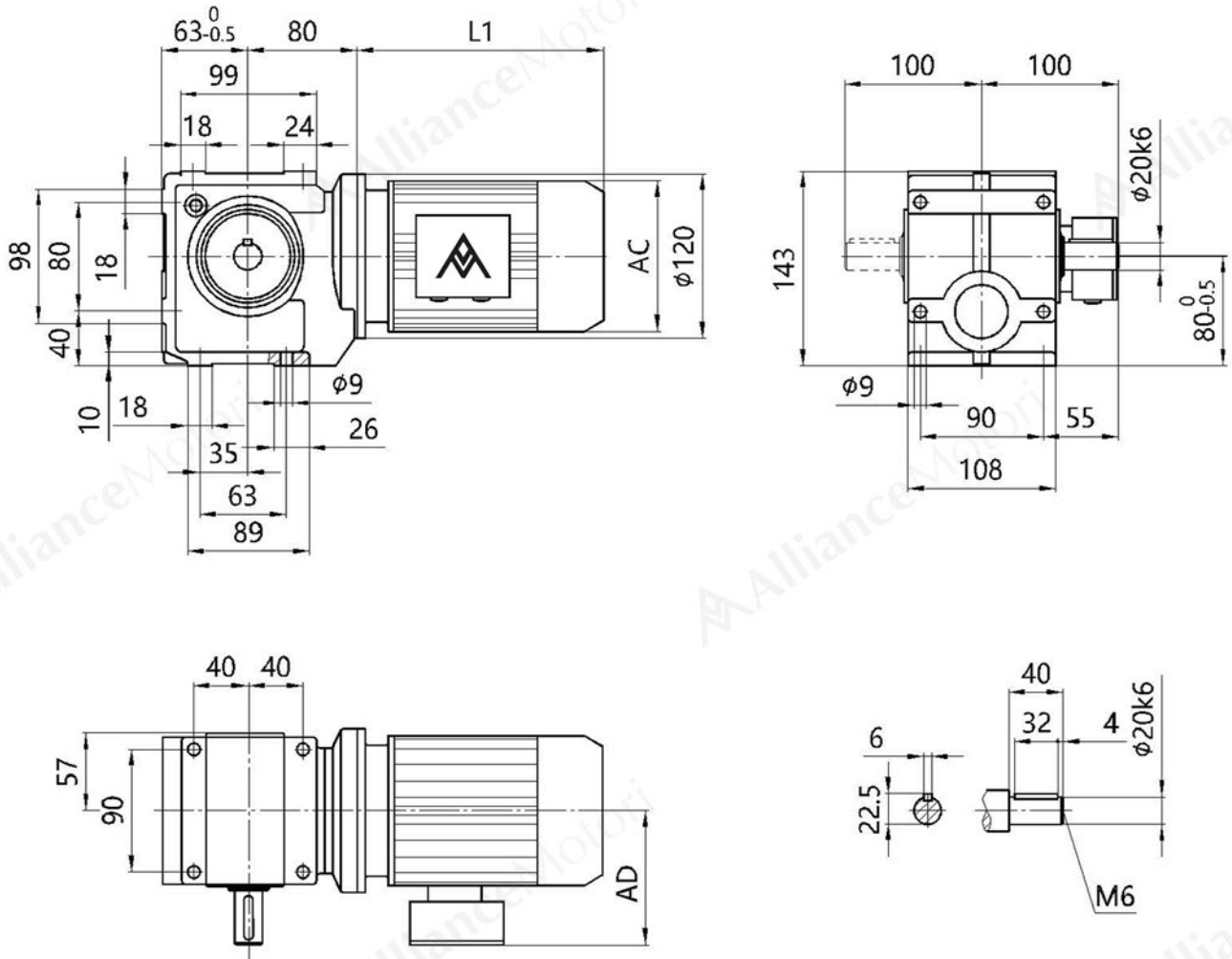

Note: When equipping the user's motor or the special one, the flange is required to be connected. (Please see appendix D)  
 Note: See Appendix A-2 and A-3 for dimensions of direct-connected motors

■ Mounting Dimensional Description AS49 - AS99

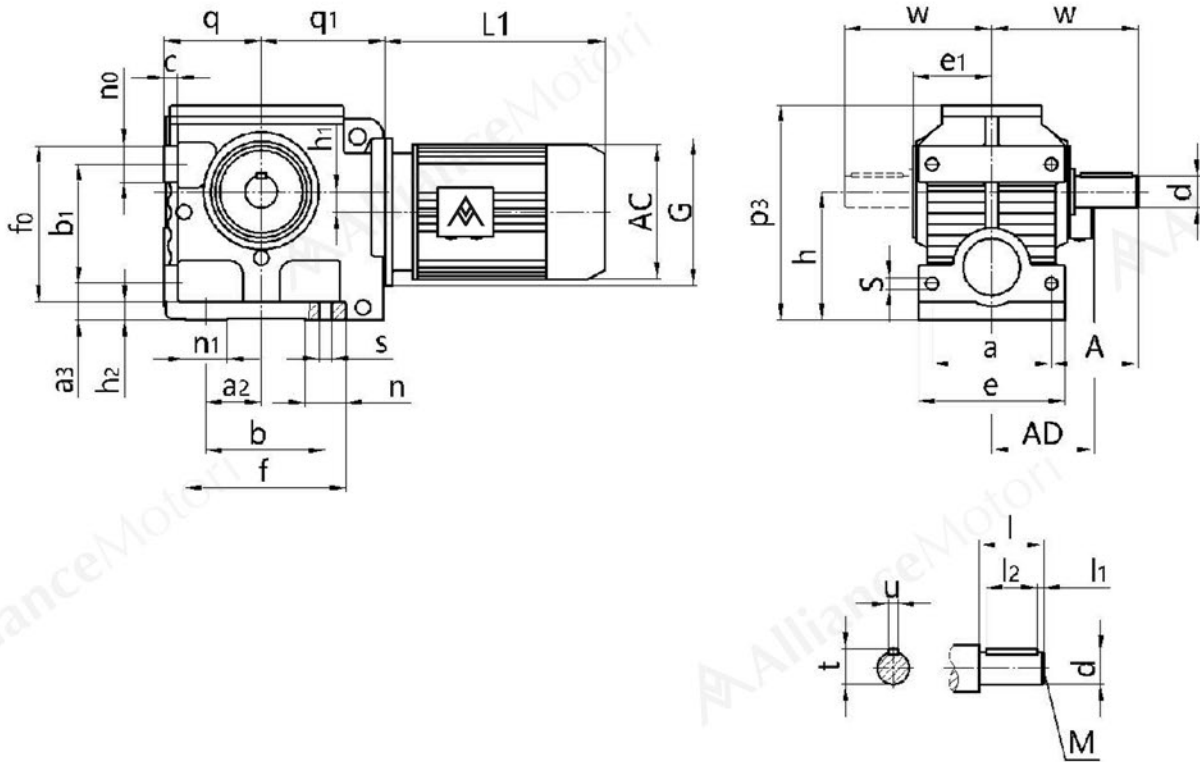

Type Size	q d	q <sub>1</sub> w	c A	f <sub>0</sub> a	b <sub>1</sub> e	n <sub>0</sub> h	a <sub>3</sub> p <sub>3</sub>	h <sub>1</sub> e <sub>1</sub>	h <sub>2</sub> u	n <sub>1</sub> t	a <sub>2</sub> l	s l <sub>1</sub>	n l <sub>2</sub>	b M	f G	Motor Size			
																AC	AD	L1	
<b>AS49</b>	75 <sup>-0.5</sup> Φ25k6	96 115	12 65	105 100	80 120	25 100 <sup>-0.5</sup>	35 167	8 60	15 8	30 28	35 50	Φ11 5	32 40	80 M10	112 Φ120	Please see appendix A-2 and A-3			
<b>AS59</b>	80 <sup>-0.5</sup> Φ30k6	107 134	12 79	130 110	100 136	30 112 <sup>-0.5</sup>	35 190	20 71	15 8	30 33	45 60	Φ11 3.5	30 50	100 M10	130 Φ120				
<b>AS69</b>	106 <sup>-0.5</sup> Φ35k6	135 160	15 95	170 130	130 160	40 140 <sup>-0.5</sup>	40 238	22 85.5	20 10	45 38	60 70	Φ13.5 7	45 56	130 M12	175 Φ160				
<b>AS79</b>	125 <sup>-0.5</sup> Φ45k6	162 195	25 120	177 150	135 185	42 180 <sup>-0.5</sup>	70 304	34 101	25 14	50 48.5	75 90	Φ17.5 5	69 80	135 M16	204 Φ200				
<b>AS89</b>	150 <sup>-0.5</sup> Φ60m6	190 255	30 155	230 200	180 250	50 225 <sup>-0.5</sup>	82 372	37.5 130	30 18	60 64	92 120	Φ22 5	67 110	180 M20	247 Φ250				
<b>AS99</b>	180 <sup>-0.5</sup> Φ70m6	240 295	35 170	295 250	235 300	60 280 <sup>-1</sup>	90 461	52 150	35 20	80 74.5	115 140	Φ26 7.5	85 125	235 M20	320 Φ300				

Note:the dimensions don't include the height of the breathe valve.the height of the breathe valve is 17.

Note:When equipping the user's motor or the special one, the flange is required to connected. (Please see appendix D)

■ Mounting Dimensional Description AS109 / ASF109

AS109

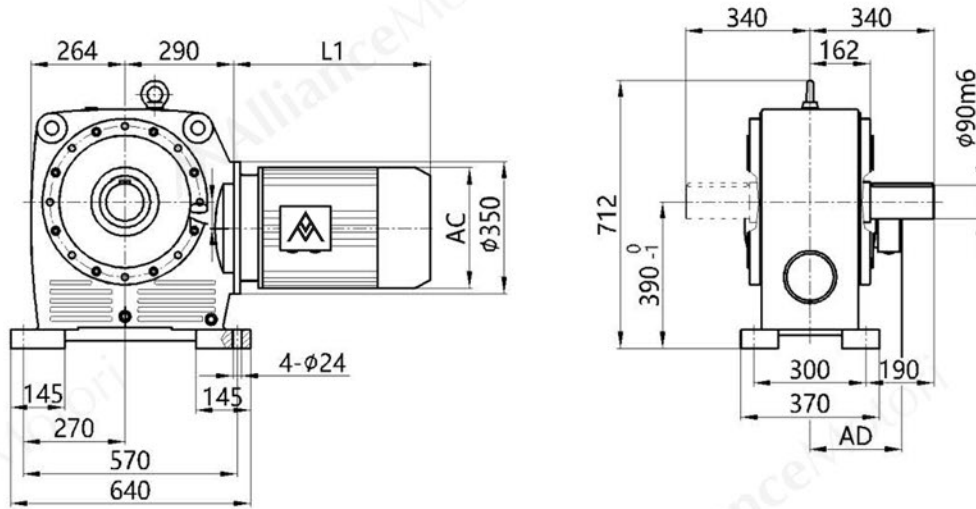

ASF109

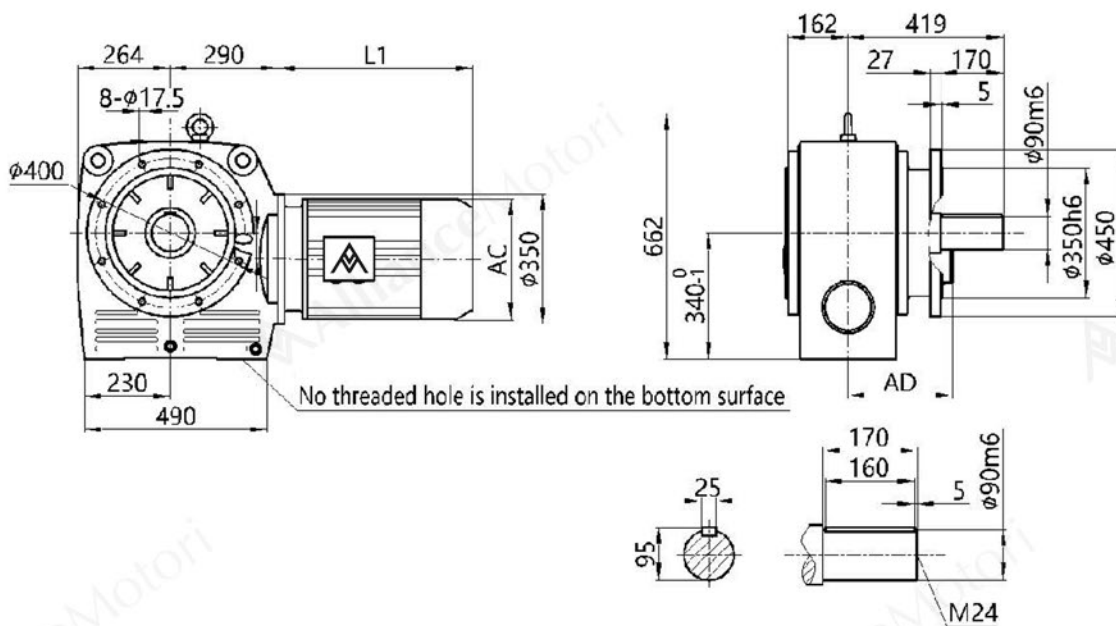

Note: When equipping the user's motor or the special one, the flange is required to be connected. (Please see appendix D)

Note: See Appendix A-2 and A-3 for dimensions of direct-connected motors